

# ***GR*reddy**®

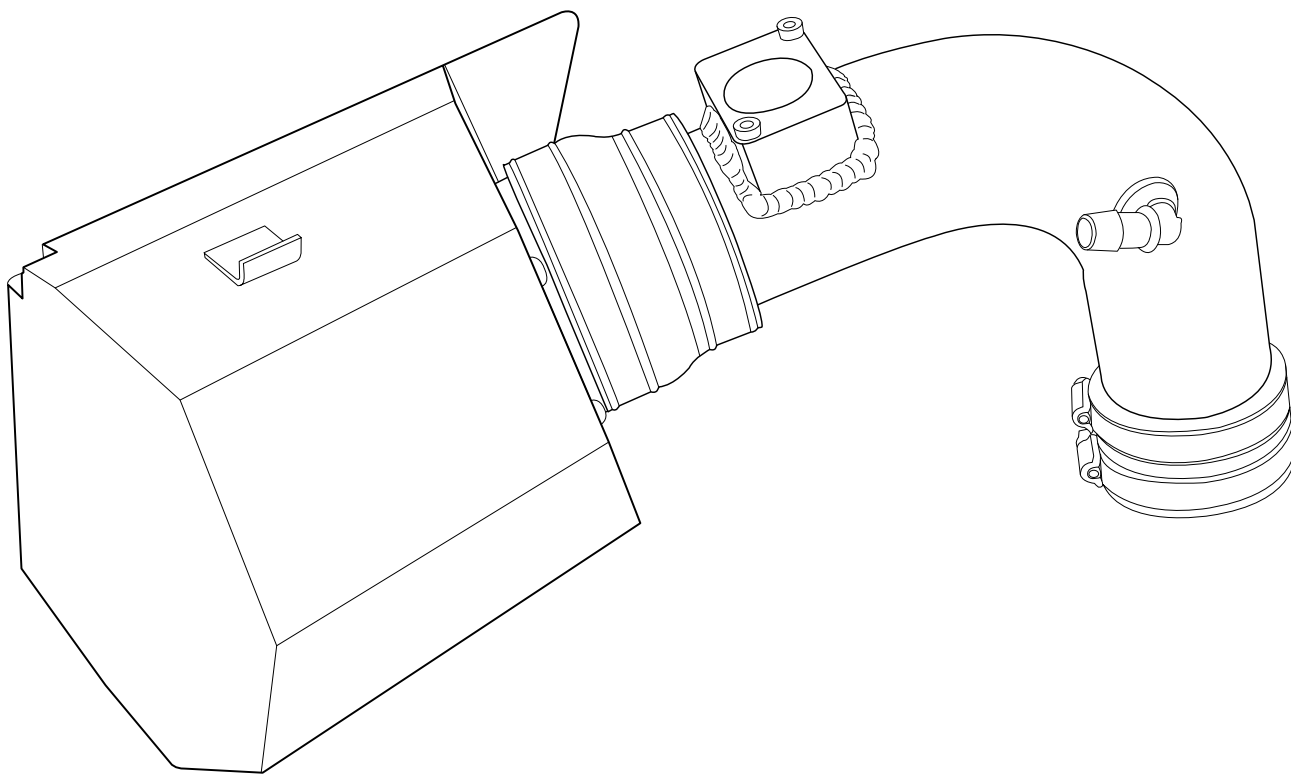

## **Instruction Manual** P/N: 12539003

Make: **Mitsubishi** Model: **Lancer GTS** Year: **2009-2011** Engine: **L4-2.4L**



- Please read the entire instruction manual before proceeding.
- Ensure all components listed are present.
- If you are missing any of the components, call customer support at 949-588-8300.
- Ensure you have all necessary tools before proceeding.
- Do not attempt to work on your vehicle when the engine is hot.
- Disconnect the negative battery terminal before proceeding.
- Retain factory parts for future use.

Label	Qty.	Description	Part Number
A	1	Pro Dry S Air Filter	61-90134
B	1	Intake Tube	05-T4203P1 (Pol)
C	1	Housing	05-T4203B2
D	1	Adaptor	05-01037
E	1	Coupler, Straight	03-00417
F	1	Coupler, Reducer	05-00824
G	1	Clamp, 56	03-50009
H	1	Clamp, 48	03-50007
I	2	Clamp, 44	03-50019
J	1	Grommet	03-50050
K	1	Elbow Fitting	03-50152
L	3	Screw, Button Head	03-50102
M	2	Screw, Cheese Head	03-50030

Installation will require the following tools:

Flat head screw driver, Phillips screw driver, 8mm socket, 10mm socket, Ratchet & 5/16 nut driver.

Note: Legal in California for use on race vehicles only. The use of this device on vehicles used on public streets or highways is strictly prohibited in California and others states that have adopted California emission regulations.



B



C



D



E

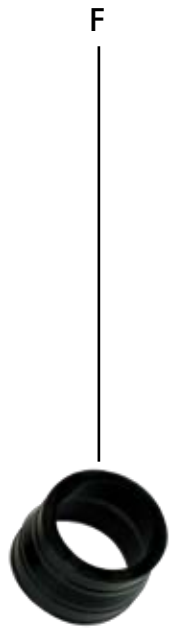

F



G



H



I



J



K



L



M



A

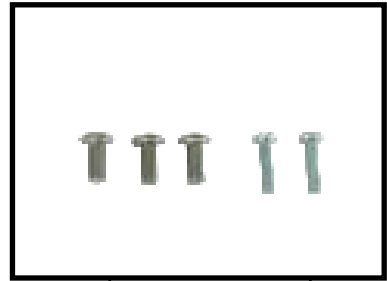

L

M

**Refer to Figure A for step 1**

Step 1: Remove the air inlet assembly from the vehicle (1). Disconnect the wiring harness from the Mass Air Sensor (MAS) (2). Remove the crankcase breather hose and plastic elbow from the air intake tube (3). Loosen the clamps securing the air intake tube (4) and remove the air intake tube from the vehicle. Release the clips (2) (5) securing the airbox cover. Remove the airbox cover (6) and filter element. Remove the MAS from the stock intake tube.



Figure B

**Refer to Figure B for step 2**

Step 2: Install the rubber grommet (J) and plastic elbow (K) in the supplied air intake tube (B).



**Refer to Figure C for step 3**

Step 3: Attach the air filter adapter (D) to the air filter housing (C) using the supplied button head screws (L). Install the supplied air filter (A) on the air filter adapter and tighten the clamp.

Step 4: Install the air filter housing on the stock air filter housing and secure the rear clip (5) (the front clip is no longer used).



Figure D

### **Refer to Figure D for steps 5-6**

Step 5: Loosely install the supplied couplings (E) (F) and clamps (G) (H) (I) on the air intake tube.

Step 6: Install the air intake tube between the throttle body and air filter housing. Align the tube and tighten the clamps. Install the MAS & connect the wiring harness (2) to the MAS and attach the crankcase breather hose (3). Finish the installation by replacing the air inlet assembly (1).

Page left blank intentionally



Page left blank intentionally

Pro DRY S Air Filter



P/N: 61-90134

To purchase any of the items above, view airflow charts, dyno graphs, photos, and video; please go to [Greddy.com](http://Greddy.com).

Page left blank intentionally

***GR*Reddy®**

***GR*Reddy Performance Products**

**9 Vanderbilt, Irvine CA 92618**

**TEL: 949.588.8300 • E-Mail: Tech@greddy.com**